



TCA-54

重荷重用キャスター

Caster (Heavy Load Use)



特長
重荷重用のキャスターです。

用途
OA 機器・台車等

Characteristic
Caster for heavy load use.

Application
Office automation appliances / Wagons, etc

■部品表 Parts List

部品名 Part Name	材質 Material	処理 Finish
本体 Main Body	SPHC	3 価クロメート Trivalent Chromate Treatment
車輪 Wheel	PA	黒色 Black

※本体の処理は TCA-54SS の場合は 3 価クロメート (黒) です。

※ The finish of body for TCA-54SS is trivalent chromate treatment (Black).

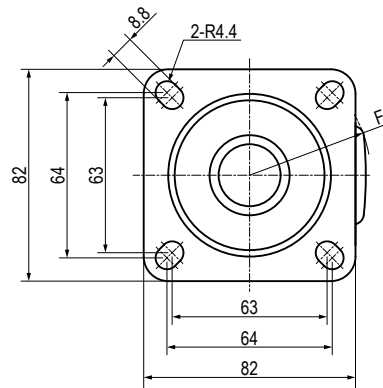
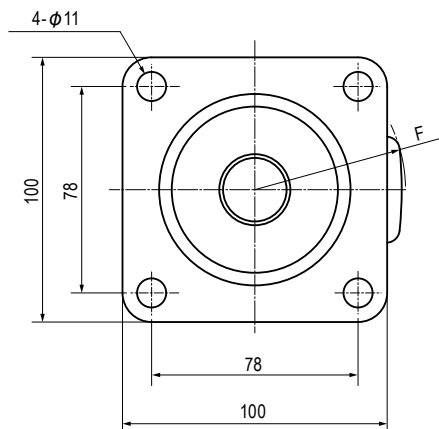

TCA-54NL-NRB50の場合
TCA-54NL-NRB50

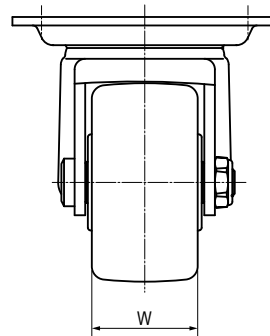
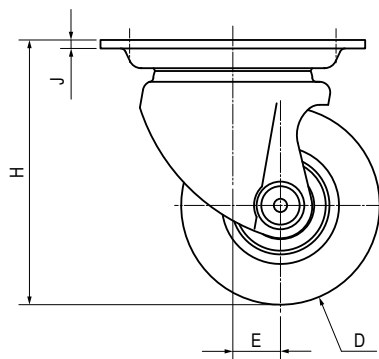

寸法・仕様表 Size List & Specification

型番 Model No.	D	E	F	H	J	W	許容荷重 (kg) Allowable Load (kg)	自重 (g) Net Weight (g)
TCA-54NL-NRB50	φ50	20	(R47)	79	t3.2	38	306	757
TCA-54SS-NRB65	φ65	22	(R58)	90		40	285.6	926
TCA-54LL-NRB65		18	(R53)	95			408	940
TCA-54WW-NRB65			(R52)	97				957
TCA-54NW-NRB65		φ75	23	(R63)	100		t3.5	45
TCA-54SS-NRB75	18		(R58)	105	612	1017		
TCA-54WW-NRB75	16		(R57)	107		1338		
TCA-54NW-NRB75				1352				