



## TCA-G型 双輪キャスター

G-type Twin Wheel Caster



### 特長

双輪ですので旋回半径が少なくデザインも優れています。

### 用途

大型 OA 機器等

### 材質と処理 Material & Finish

部品名	Part Name	材質	Material	処理	Finish
本体	Body	ADC		バレル研磨	Barrel Polishing
車輪	Wheel	PA		黒色	Black

### Characteristic

Small turning radius with its twin wheels.

### Application

Large size office automation appliances, etc.

### G7N□S (ストッパー付)

with stopper

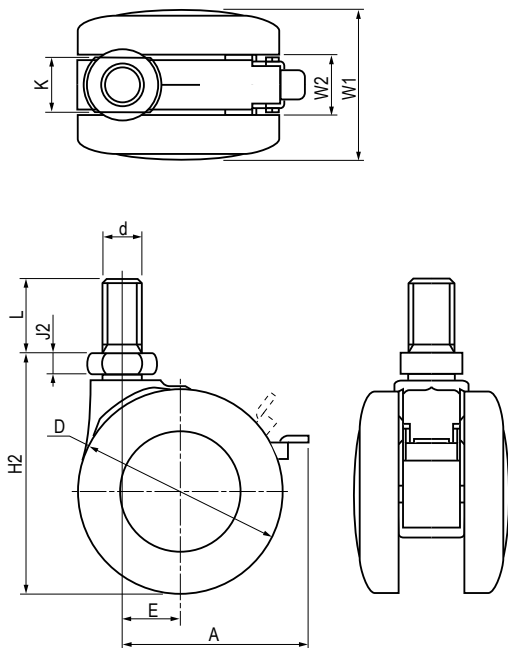

### G7S (ストッパー付)

with stopper

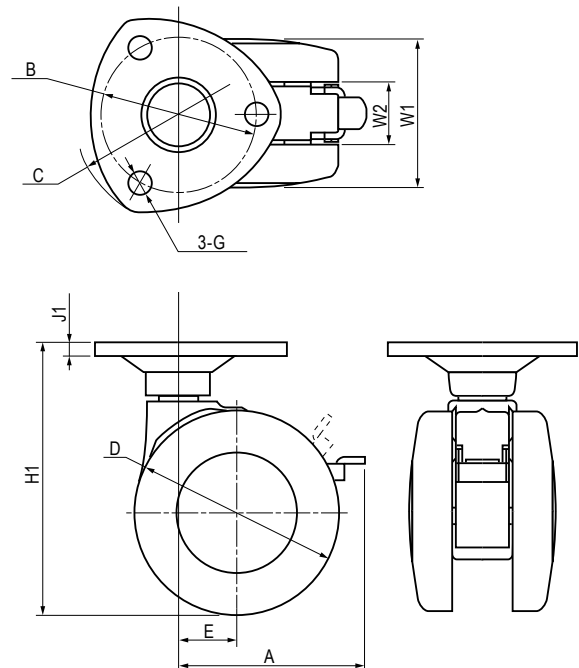

### 寸法・仕様表 Size List & Specification

型番 Model No.	A	B	C	D	E	G	d	H1	H2	J1	J2	K	L	W1	W2	型式 Type		許容荷重 (kg) Allowable Load (kg)	自重 (g) NetWeight (g)																								
																形状 Shape	ストッパー Stopper																										
TCA-G7	—	—	—	—	—	—	—	—	—	—	—	—	—	—	—	—	プレート式 Plate type	—	250																								
TCA-G7S	55	φ48	φ62	—	—	φ6.5	—	79.5	—	t3.8	—	—	—	—	—	—	プレート式 Plate type	付き With Stopper	264																								
TCA-G7N3	—	—	—	—	—	—	—	—	—	—	—	—	—	—	—	—	ネジ式 Bolt type	—	178																								
TCA-G7N3S	55	—	—	φ60	17	—	W3/8	—	70	—	t6	17	19	44	18	—		付き With Stopper	192																								
TCA-G7N10	—	—	—															—	—	—	—	—	—	—	—	—	—	—	—	—	—	178											
TCA-G7N10S	55	—	—															—	—	M10	—	—	—	—	—	—	—	—	—	—	付き With Stopper	192											
TCA-G7N12	—	—	—															—	—	M12	—	—	—	—	—	—	—	—	—	—	—	188											
TCA-G7N12S	55	—	—															—	—												—	—	—	—	—	—	—	—	—	—	—	付き With Stopper	202

特注品のご相談承ります Please contact us for custom-made.