



THA-185 モールド取手

Carrying Handle



特長

取手部に板ばねを使用しています。

用途

計測機器・通信機器等

Characteristic

A plate spring is used in the handle.

Application

Measuring instruments /
Telecommunication devices, etc.

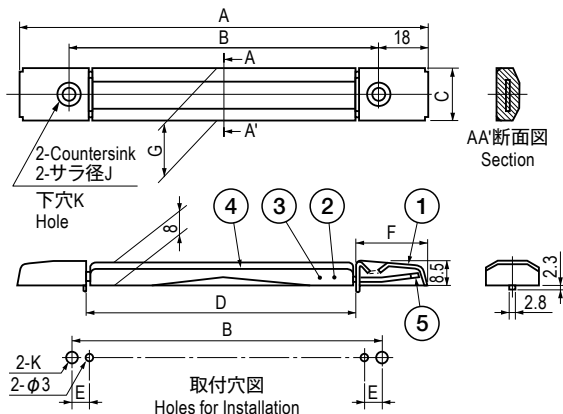

■部品表 Parts List

部番 No.	部品名 Part Name	材質 Material	処理 Finish	数 Quantity
1	止め金具 Face	C2801	Cr (梨地) Cr (Satin Finish)	2
2	板ばね Plate Spring	SK	—	1
3	リベット Rivet	S		4
4	モールド Mold	エラストマー Elastomer	Ni	1
5	金具 Base	C2801		2

寸法・仕様表 Size List & Specification

型番 Model No.	A	B	C	D	E	F	G	J	K	垂直許容荷重 N (kgf) Allowable Vertical Load N (kgf)	自重 (g) Net Weight (g)
THA-185-1	(174)	138	24	122	7.5	26	24	φ10.6	φ5.3	294 (30)	65
THA-185-2	(148)	112	20	98	6.5	25	20	φ8.6	φ4.3	245 (25)	48