



TM-203F / TM-203MF TM-203SUS アイボルト(首長)

Eye Bolt (Long Neck)

SUS

取扱品
PRODUCT

TSCA
PBT5

RoHS2
10

特長

JIS規格よりもネジ部を長くしていますので、厚肉のパネルにも充分対応できます。

用途

配電盤・分電盤・制御盤・工作機械等

仕様

付属品：スプリングワッシャー、平ワッシャー、ナット 各1個

Characteristic

The length of screw is set longer than JIS standard so that it can be used for a thicker panel.

Application

Distribution boards / Distribution panels / Control boards / Machine tools, etc.

Specification

Accessories: Spring Washer, Flat Washer, Nut 1 each

材質と処理 Material & Finish

型番 Model No.	材質 Material	処理 Finish
TM-203F	SS400	—
TM-203MF		3価クロメート Trivalent Chromate Treatment
TM-203SUS	SUS304	—

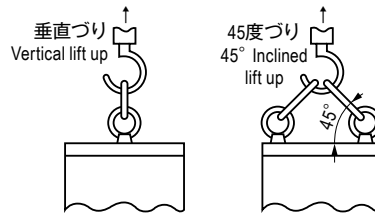
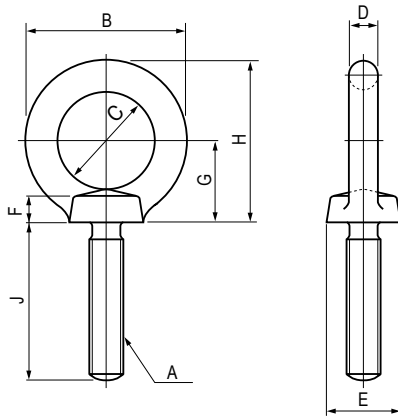

※45度つりの使用荷重は、ザグリなどを施しボルトの座面が相手と密着し、2個のボルトのリングの向きが左図のように同一平面内にある場合に適用します。

※Application load for 45° inclined lift up applies when 2 bolts are set to be contacted with the subject by means of spot facing or others and 2 rings are aligned on the same plane shown in the figure on left side.

寸法・仕様表 Size List & Specification TM-203F

型番 Model No.	A(ねじの呼び) Nominal Size of Screw	B	C	D	E	F	G	H(参考) Reference	J	使用荷重 kN (kgf) Application Load kN (kgf)		自重 (g) Net Weight (g)
										垂直つり Vertical lift up	45度つり(2個につき) 45° Inclined lift up (for 2 bolts)	
TM-203F-2	M8	32.6	20	6.3	16	5	17	33.3	50	0.79 (80)	0.79 (80)	
TM-203F-3	M10	41	25	8	20	7	21	41.5		1.47 (150)	1.47 (150)	
TM-203F-4	M12	50	30	10	25	9	26	51		2.16 (220)	2.16 (220)	
TM-203F-5	M16	60	35	12.5	30	11	30	60		4.41 (450)	4.41 (450)	
TM-203F-6	M20	72	40	16	35	13	35	71		6.18 (630)	6.18 (630)	

寸法・仕様表 Size List & Specification TM-203MF

型番 Model No.	A(ねじの呼び) Nominal Size of Screw	B	C	D	E	F	G	H(参考) Reference	J	使用荷重 kN (kgf) Application Load kN (kgf)		自重 (g) Net Weight (g)
										垂直つり Vertical lift up	45度つり(2個につき) 45° Inclined lift up (for 2 bolts)	
TM-203MF-2	M8	32.6	20	6.3	16	5	17	33.3	50	0.79 (80)	0.79 (80)	51
TM-203MF-3	M10	41	25	8	20	7	21	41.5		1.47 (150)	1.47 (150)	93
TM-203MF-4	M12	50	30	10	25	9	26	51		2.16 (220)	2.16 (220)	166
TM-203MF-5	M16	60	35	12.5	30	11	30	60		4.41 (450)	4.41 (450)	308
TM-203MF-6	M20	72	40	16	35	13	35	71		6.18 (630)	6.18 (630)	551

寸法・仕様表 Size List & Specification TM-203SUS

型番 Model No.	A(ねじの呼び) Nominal Size of Screw	B	C	D	E	F	G	H(参考) Reference	J	使用荷重 kN (kgf) Application Load kN (kgf)		自重 (g) Net Weight (g)
										垂直つり Vertical lift up	45度つり(2個につき) 45° Inclined lift up (for 2 bolts)	
TM-203SUS-2	M8	32.6	20	6.3	16	5	17	33.3	50	0.79 (80)	0.79 (80)	53
TM-203SUS-3	M10	41	25	8	20	7	21	41.5		1.47 (150)	1.47 (150)	99
TM-203SUS-4	M12	50	30	10	25	9	26	51		2.16 (220)	2.16 (220)	177
TM-203SUS-5	M16	60	35	12.5	30	11	30	60		4.41 (450)	4.41 (450)	316
TM-203SUS-6	M20	72	40	16	35	13	35	71		6.18 (630)	6.18 (630)	547

特注品のご相談承ります Please contact us for custom-made.