



TM-236 / TM-237 アジャスターフット

Level Adjuster



特長

接地面にゴムを使用した、滑り止め効果のあるアジャスターフットです。キャスターとの併用により、一層便利にご使用いただけます。

用途

コンピューター・計測機器・OA 機器・その他筐体等

Characteristic

This adjustable foot has rubber on the contact surface, effectively preventing slippage. Can be combined with casters to assist mobility. Five different standard screw sizes are available for various application.

Application

Computers / Measuring instruments / Office automation appliances / Other boxes, etc.

■部品表 Parts List

部番 No.	部品名 Part Name	材質 Material	処理 Finish	数 Quantity
1	アジャストボルト Adjuster Bolt	SWCH	3 価クロメート (黒) Trivalent Chromate Treatment (Black)	1
2	ナイロンワッシャー Nylon Washer	PA	原色 Primary Color	1
3	フット Foot	SPCC	3 価クロメート (黒) Trivalent Chromate Treatment (Black)	1
4	ホルダー Holder	EPDM	黒色 Black (TM-236) 灰色 Gray (TM-237)	1
5	止めねじ Set Screw	S	3 価クロメート Trivalent Chromate Treatment	1

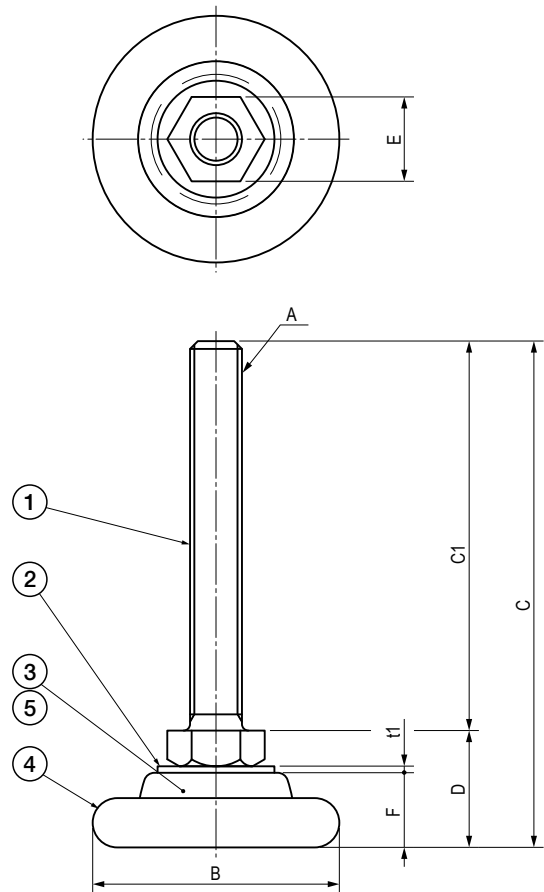

寸法・仕様表 Size List & Specification TM-236

型番 Model No.	A	B	C	C1	D	E	F	垂直圧縮許容荷重 kN (kgf) Allowable Vertical Compressive Load kN (kgf)	自重 (g) Net Weight (g)
TM-236-1	M8 × 1.25	φ38	(78)	60	18	13	(12.5)	0.78 (80)	44
TM-236-2	M10 × 1.5		(69.5)	50	19.5	17	(11.5)		58
TM-236-3	M12 × 1.75	φ60	(94)	70	24	19	(15)	1.96 (200)	141
TM-236-4	M16 × 2		(96)		26	24			203

寸法・仕様表 Size List & Specification TM-237

型番 Model No.	A	B	C	C1	D	E	F	垂直圧縮許容荷重 kN (kgf) Allowable Vertical Compressive Load kN (kgf)	自重 (g) Net Weight (g)
TM-237-1	M8 × 1.25	φ38	(78)	60	18	13	(12.5)	0.78 (80)	44
TM-237-2	M10 × 1.5		(69.5)	50	19.5	17	(11.5)		58
TM-237-3	M12 × 1.75	φ60	(94)	70	24	19	(15)	1.96 (200)	141
TM-237-4	M16 × 2		(96)		26	24			203