



TM-258 / TM-258S

アジャスターフット

Level Adjuster



特長

幅広いニーズにお応えするため、材質をステンレス製、鉄製の2種類用意いたしました。

フット部が鋳物製のため重量用に使用できます。

用途

OA 機器・自動販売機・工作機械・その他

Characteristic

Two types, stainless steel made and steel made, are available. The foot is made of cast material to support heavy weight subjects.

Application

Office automation appliances / Vending machines / Machine tools / Others

■部品表 Parts List

部番 No.	部品名 Part Name	TM-258		TM-258S		数 Quantity
		材質 Material	処理 Finish	材質 Material	処理 Finish	
1	シャフト Shaft	S	3 価クロメート	SUS304	-	1
2	フット Foot	SS400	Trivalent Chromate Treatment			1
3	ナット Nut	S				1

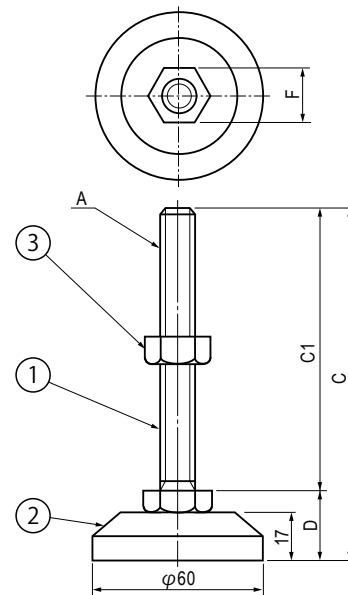

寸法・仕様表 Size List & Specification TM-258

型番 Model No.	A	C	C1	D	F	垂直圧縮許容荷重 kN (kgf) Allowable Vertical Compressive Load kN (kgf)	自重 (g) Net Weight (g)
TM-258-1	M12 × 1.75	(75)	50	25	19	2.94 (300)	305
TM-258-2		(125)	100				345
TM-258-3		(145)	120				360
TM-258-4		(175)	150				380
TM-258-5	M16 × 2	(92)	65	27	24	6.87 (700)	395
TM-258-6		(127)	100				440
TM-258-7		(157)	130				485
TM-258-8		(177)	150				510
TM-258-9	M20 × 2.5	(207)	180	30	30	8.83 (900)	550
TM-258-10		(130)	100				590
TM-258-11		(160)	130				650
TM-258-12		(180)	150				695
TM-258-13		(210)	180				750
TM-258-14	(230)	200	800				

寸法・仕様表 Size List & Specification TM-258S

型番 Model No.	A	C	C1	D	F	垂直圧縮許容荷重 kN (kgf) Allowable Vertical Compressive Load kN (kgf)	自重 (g) Net Weight (g)
TM-258S-2	M12 × 1.75	(125)	100	25	19	2.94 (300)	350
TM-258S-3		(145)	120				365
TM-258S-6	M16 × 2	(127)	100	27	24	6.87 (700)	445
TM-258S-7		(157)	130				490
TM-258S-9		(207)	180				555
TM-258S-10	M20 × 2.5	(130)	100	30	30	8.83 (900)	595
TM-258S-11		(160)	130				660
TM-258S-13		(210)	180				760

特注品のご相談承ります Please contact us for custom-made.